



Torque Range

1.750 ... 60.000 Nm

Gear Ratios

5,8 ... 153

Key Features

- Rotating housing flange with studs to fit wheels and drums
- Rugged design
- High torque capacity
- High load capacity
- Mechanical lifetime seals
- Compact design
- Optional mechanical gear disengagement on request

Applicable motors

- Cartridge axial piston hydraulic motors
- Flanged axial piston hydraulic motors
- Hydraulic orbit motors
- DC electric motors

Brake

Hydraulically released parking brake on request

Type	Max. Torque Nm	Range of ratios 1:	Max. input speed min-1	Hydraulic motor drive (1)	Braking torque Nm	Min. opening pressure bar	Weight Kg	Design
601 R	1750	5,77	500	LS	450 - 600	15 - 20	35	A
603 W..V	4000	19-23-32-40	3000	HS	210	18	45	B
603 W..L	4000	19-23-32-40	3000	HS	210	18	45	A
605 W..V	7000	22-27-30-42-53	3000	HS	220 - 310	10 - 20	70	B
606 W..V	12000	30- 35-43-68-79	3000	HS	300 - 800	15 - 20	110	B
607 W..V	17000	33-75-108	3000	HS	300 - 600	15 - 20	140	B
609 W..V	23000	33-142	3000	HS	300 - 600	15 - 20	170	B
610 W..V	30000	20 - 111	3000	HS	300 - 800	15 - 20	200	B
611 W..V	36000	41-47	3000	HS	300 - 800	15 - 20	250	B
613 W..V	45000	108	3000	HS	300 - 800	15 - 20	250	B
615 W..V	60000	108	3000	HS	300 - 1000	15 - 20	350	B

(1) LS = Low speed motor
HS = High speed motor

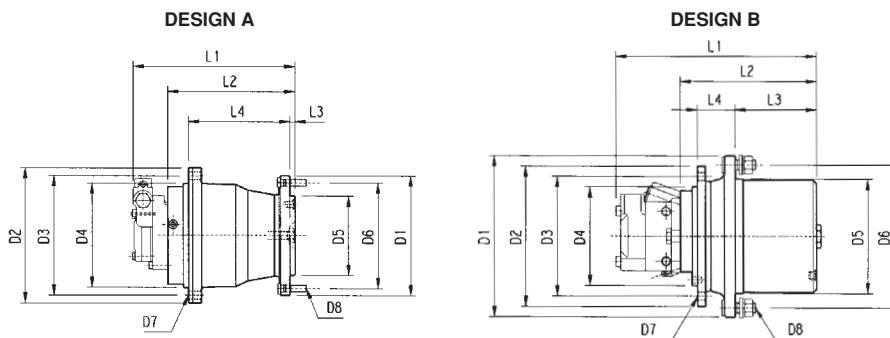

Type	Dimensions												
	D1	D2	D3	D4	D5	D6	D7	D8	L1	L2	L3	L4	
601 R	230	260	230	200	152.4	203.2	15 n°8	M14x1,5 n°8		245	10	195	
603 W..V	280	270	230	190	200	245	M16x2 n°8	M18x1,5 n°6		230	128	72	
603 W..L	280	270	230	190	160	205	M16x2 n°8	M18x1,5 n°6		230	25	175	
605 W..V	310	270	230	190	220	275	M16x2 n°8	M20x1,5 n°6		260	158	72	
606 W..V	370	330	300	270	280	335	M16x2 n°18	M22x1,5 n°10		330	200	115	
607 W..V	410	380	285	240	320	380	M20x2,5 n°20	M18x1,5 n°20		340	230	82	
609 W..V	435	380	285	240	350	400	M20x2,5 n°20	M20x1,5 n°16		350	240	91	
610 W..V	435	375	340	300	350	400	M20x2,5 n°16	M22x1,5 n°16		375	253	91	
611 W..V	490	425	325	290	410	455	M20x2,5 n°24	M20x1,5 n°24		375	242	110	
613 W..V	490	425	325	280	410	455	M20x2,5 n°24	3/4-16 UNF n°24		405	275	110	
615 W..V	550	500	460	420	460	510	M20x2,5 n°24	M20x1,5 n°24		470	320	130	

HEADQUARTERS

BONFIGLIOLI RIDUTTORI
Via Giovanni XXIII, 7/A
40012 Lippo di Calderara di Reno
Bologna (ITALY)
Tel. (+39) 051 6473111
Fax (+39) 051 6473126
www.bonfiglioli.com

SALES DEPARTMENT

BONFIGLIOLI RIDUTTORI S.p.A.
Via Enrico Mattei,12 - Z.I. Villa Selva
47100 Forlì (ITALY)
Tel. (+39) 0543 789111
Fax (+39) 0543 789242 - 0543 789245
trasmital@bonfiglioli.com

