

INDUSTRY PROCESS
AND AUTOMATION SOLUTIONS



BONFIGLIOLI
RIDUTTORI

RAP



BONFIGLIOLI

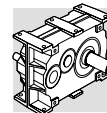

RIDUTTORI AD ASSI PARALLELI PARALLEL SHAFT GEAR UNITS

RAP

Capitolo Chapter	Descrizione	Description	
1	Designazione	<i>Designation</i>	2
2	Forme costruttive	<i>Versions</i>	3
3	Opzioni	<i>Options</i>	3
4	Dispositivo antiretro	<i>Anti-run back device</i>	4
5	Lubrificazione	<i>Lubrication</i>	4
6	Posizioni di montaggio	<i>Mounting positions</i>	5
7	Prestazioni nominali	<i>Rating chart</i>	6
8	Dimensioni d'ingombro	<i>Installation drawings</i>	13
9	Perno macchina	<i>Customer's shaft</i>	28
10	Installazione riduttore con calettatore	<i>Installation of the shrink disc</i>	29
11	Calcolo del carico radiale	<i>Calculation of radial load</i>	30
12	Predisposizioni attacco motore	<i>Motor adapters</i>	31

Revisioni

L'indice di revisione del catalogo è riportato a pag. 32.
Nel sito www.bonfiglioli.com sono disponibili i cataloghi con le revisioni aggiornate.

Revisions

Refer to page 32 for the catalogue revision index.
Check on www.bonfiglioli.com for latest revision of each catalogue.

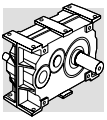

1 - DESIGNAZIONE

1 - DESIGNATION

RAP 60 D N A 60.8 132 B5 B3 ...

OPZIONI / GEAR OPTIONS
LO, AL, PV

3

POSIZIONE DI MONTAGGIO / MOUNTING POSITION
B3, B8, V1, V3, VA, VB

5

MONTAGGIO MOTORE / MOTOR MOUNTING
B5

DESIGNAZIONE INGRESSO / INPUT DESIGNATION

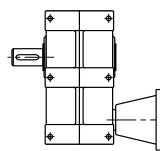

IEC

080	180
090	200
100-112	225
132	250
160	280

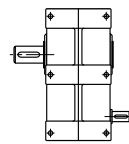

HS

RAPPORTO / GEAR RATIO

ANTIRETRO / BACKSTOP
A

4

FORMA COSTRUTTIVA / VERSION
N, LS, C, CC, LD, VD, VL, LC, LCC

3

- DUE STADI DI RIDUZIONE / DOUBLE REDUCTION
- D** TRE STADI DI RIDUZIONE / TRIPLE REDUCTION

GRANDEZZA RIDUTTORE / FRAME SIZE
45, 60, 70, 90, 100, 110, 130

TIPO / TYPE

RAP = RIDUTTORE AD ASSI PARALLELI / PARALLEL SHAFT GEAR UNIT

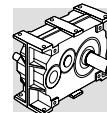

2 - FORME COSTRUTTIVE

2 - VERSIONS

	B3	B8		B3	B8
N			VD		
LS			VL		
C			LC		
CC			LCC		
LD					

Default

3 - OPZIONI

LO

I riduttori sono riempiti in fabbrica con carica di lubrificante sintetico del tipo correntemente utilizzato da BONFIGLIOLI RIDUTTORI, in quantità dipendente dalla posizione di montaggio specificata.

PV

Dotazione di anelli di tenuta in Viton®.

AL

Specifica del dispositivo antiretro con rotazione libera antioraria.

3 - OPTIONS

LO

Gearbox is factory filled with synthetic lubricant of the type currently used by BONFIGLIOLI RIDUTTORI according to the mounting position specified.

PV

Oil seals from Viton® compound.

AL

Backstop is set to allow shaft rotation in the CCW direction.

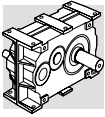

4 - DISPOSITIVO ANTIRETRO

Su richiesta, può essere installato il dispositivo antiretro, che permette la rotazione dell'albero lento solo nel senso desiderato.

In fase di ordine specificare il senso di rotazione (antiorario o orario). Se non specificato il riduttore viene fornito con il senso di rotazione destro.

Senso di rotazione

4 - ANTI-RUN BACK DEVICE

An anti-run back device is available upon request to allow rotation of the output shaft in one direction only. Please specify in the order the required direction of rotation (CW or CCW). If not otherwise specified the gearbox is supplied with the CCW rotation locked.

Direction of rotation

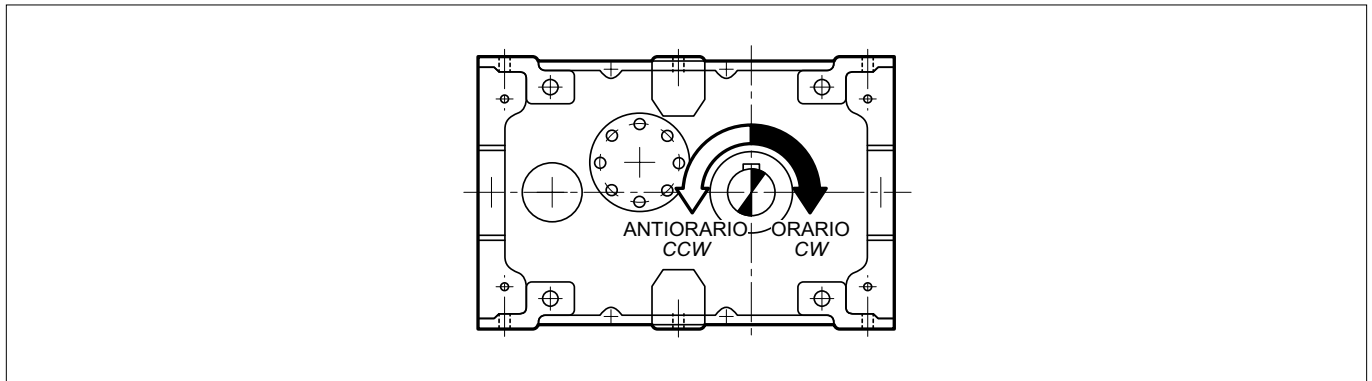

5 - LUBRIFICAZIONE

I riduttori ad assi paralleli tipo RAP sono lubrificati per sbattimento d'olio e normalmente forniti a secco.

Sarà quindi cura del Cliente immettere la giusta quantità di lubrificante prima della messa in opera del riduttore. A questo scopo i gruppi suddetti sono dotati di tappi di servizio che sono disposti in funzione della posizione di montaggio specificata in fase di ordinativo.

Nelle posizioni di montaggio V1, V3 e VA dei gruppi tipo RAP (ad eccezione di RAP 90) un tappo di sfiato dotato di astina di livello sostituisce il vetro spia, normalmente adottato per le posizioni di montaggio B3, B8 e VB.

Ricordiamo che i lubrificanti sintetici sono idonei per impiego con temperature ambiente nel campo -15 /+50 °C, e inoltre garantiscono un intervallo di sostituzione all'incirca triplo rispetto ad un corrispondente olio a base minerale.

La tabella sotto riportata indica le quantità di lubrificante in relazione alla posizione di montaggio dei singoli riduttori. Quantità espresse in litri.

5 - LUBRICATION

Gear units of the RAP series are oil splash lubricated and, unless the LO option is specified, supplied without oil charge.

It will therefore be the customer care to fill the gearbox with oil prior to putting the same into operation.

For this purpose RAP units feature oil fill, level and drain plugs located at the factory according to mounting position specified on the ordering code.

For mounting positions V1, V3 and VA a breather plug with dipstick replaces the sight glass normally used for the B3, B8 and VB mounting positions (except RAP 90).

Synthetic lubricants are preferred to mineral oils as far as the extended ambient temperature range and the approximately three times longer oil change interval.

Chart below shows quantity of oil charge per each mounting position. Values are expressed in liters.

RAP	45 45 D	60 60 D	70 70 D	90	90 D	100	100 D	110	110 D	130	130 D
B3	2.9	6.8	9	18	18	33	33	52	52	63	63
B8	2.9	6.8	9	18	27	19	35	32	54	47	78
V1	4.5	11	14	32	32	44	44	57	57	90	90
V3	4.5	9.5	13	29	29	40	40	50	50	77	77
VB	4.6	11	15	30	30	42	42	65	65	83	83
VA	4.5	12	16	27	27	43	43	73	73	92	92

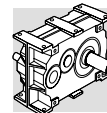

6 - POSIZIONI DI MONTAGGIO

6 - MOUNTING POSITIONS

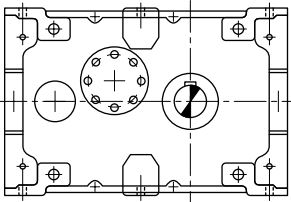
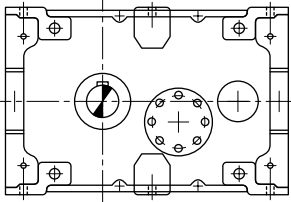
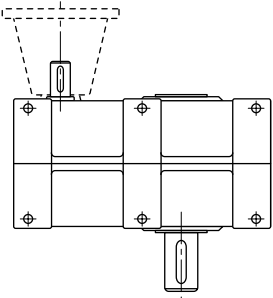
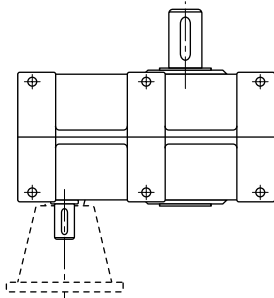
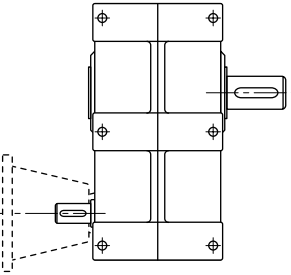
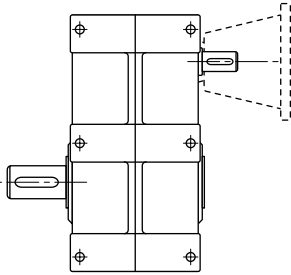
B3	B8
	
V1	V3
	
VB	VA
	



Unitamente alle posizioni di montaggio **V1**, **V3** e **VA** indicare la velocità in entrata se $n_1 < 500 \text{ min}^{-1}$.

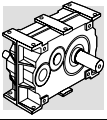

Along with the mounting position **V1**, **V3** and **VA** it is recommended that the input speed n_1 is also reported, if lower than 500 min^{-1} .





7 - PRESTAZIONI NOMINALI



7 - RATING CHART



$n_1 = 1400$	i	n_2 min^{-1}	Mn_2 Nm	Pn_1 kW	Rn_1 N	Rn_2 N 	Rn_2 N 
RAP 45	10	140	800	12.3	1500	7400	7300
	13.3	105	800	9.3	1900	8700	8800
	15	93	900	9.2	1500	8600	8500
	19.9	70	900	7.0	2000	10000	10100
	25	56	1000	6.2	1500	10500	10500
	33.2	42	1000	4.6	2000	11200	11200
RAP 45 D	45	31	1000	3.5	950	11200	11200
	59.1	23.7	1000	2.7	1100	11200	11200
	78.5	17.8	1000	2.0	1200	11200	11200
	99.6	14.1	1100	1.7	1100	11200	11200
	130.8	10.7	1100	1.3	1200	11200	11200

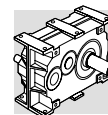

$n_1 = 900$	i	n_2 min^{-1}	Mn_2 Nm	Pn_1 kW	Rn_1 N	Rn_2 N 	Rn_2 N 
RAP 45	10	90	900	8.9	1700	8700	8600
	13.3	68	900	6.7	2200	10200	10300
	15	60	1000	6.6	1750	10200	10100
	19.9	45	1000	5.0	2250	11200	11200
	25	36	1100	4.4	1800	11200	11200
	33.2	27.1	1100	3.3	2300	11200	11200
RAP 45 D	45	20.0	1100	2.5	1100	11200	11200
	59.1	15.2	1100	1.9	1300	11200	11200
	78.5	11.5	1100	1.4	1400	11200	11200
	99.6	9.0	1200	1.2	1300	11200	11200
	130.8	6.9	1250	1.0	1400	11200	11200

$n_1 = 500$	i	n_2 min^{-1}	Mn_2 Nm	Pn_1 kW	Rn_1 N	Rn_2 N 	Rn_2 N 
RAP 45	10	50.0	1000	5.5	2200	11100	11200
	13.3	37.6	1000	4.1	2800	11200	11200
	15	33.3	1100	4.0	2300	11200	11200
	19.9	25.1	1100	3.0	2900	11200	11200
	25	20.0	1100	2.4	2500	11200	11200
	33.2	15.1	1100	1.8	3000	11200	11200
RAP 45 D	45	11.1	1200	1.5	1500	11200	11200
	59.1	8.5	1200	1.1	1700	11200	11200
	78.5	6.4	1200	0.86	1800	11200	11200
	99.6	5.0	1200	0.68	1700	11200	11200
	130.8	3.8	1200	0.52	1800	11200	11200



$n_1 = 1400$	i	n_2 min^{-1}	Mn_2 Nm	Pn_1 kW	Rn_1 N	Rn_2 N 	Rn_2 N 
RAP 60	10	140	1750	27	5300	10800	10400
	12	117	1800	23.1	5600	12000	11500
	15	93	1900	19.5	5400	12500	12300
	18	78	1900	16.3	5800	14000	13800
	25	56	2000	12.3	5600	16000	15700
	30	47	2000	10.3	5900	17500	17400
RAP 60 D	45	31	2100	7.4	4000	20500	20600
	60.8	23.0	2100	5.5	4000	22500	22500
	75	18.7	2300	4.8	4000	22500	22500
	101.3	13.8	2300	3.6	4000	22500	22500
	121.6	11.5	2300	3.0	4000	22500	22500



$n_1 = 900$	i	n_2 min^{-1}	Mn_2 Nm	Pn_1 kW	Rn_1 N	Rn_2 N 	Rn_2 N 
RAP 60	10	90	1900	18.8	6150	12900	12600
	12	75	1900	15.7	6500	14300	14100
	15	60	2000	13.2	6400	15400	15200
	18	50	2000	11.0	6500	16900	16900
	25	36	2100	8.3	6500	19100	19200
	30	30	2100	6.9	6500	21000	21000
RAP 60 D	45	20.0	2300	5.2	4000	22500	22500
	60.8	14.8	2300	3.8	4000	22500	22500
	75	12.0	2300	3.1	4000	22500	22500
	101.3	8.9	2300	2.3	4000	22500	22500
	121.6	7.4	2300	1.9	4000	22500	22500

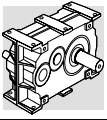

$n_1 = 500$	i	n_2 min^{-1}	Mn_2 Nm	Pn_1 kW	Rn_1 N	Rn_2 N 	Rn_2 N 
RAP 60	10	50	2000	11.0	6500	16700	16700
	12	42	2000	9.2	6500	18400	18500
	15	33	2100	7.7	6500	19800	19900
	18	27.8	2100	6.4	6500	21600	22000
	25	20.0	2300	5.1	6500	22500	22500
	30	16.7	2300	4.2	6500	22500	22500
RAP 60 D	45	11.1	2300	2.9	4000	22500	22500
	60.8	8.2	2300	2.1	4000	22500	22500
	75	6.7	2300	1.7	4000	22500	22500
	101.3	4.9	2300	1.3	4000	22500	22500
	121.6	4.1	2300	1.1	4000	22500	22500





RAP 70



3800 Nm



$n_1 = 1400$	i	n_2 min^{-1}	Mn_2 Nm	Pn_1 kW	Rn_1 N	Rn_2 N 	Rn_2 N 
RAP 70	10	140	3100	48	4000	21000	1200
	12.2	115	3100	39	4600	23500	2900
	15	93	3300	34	4300	24500	2300
	18.3	77	3300	28	4800	27000	4200
	25	56	3400	21	4600	30000	4800
	30.4	46	3400	17.2	5100	32000	6900
RAP 70 D	45	31	3600	12.7	4000	32000	8000
	60.8	23.0	3600	9.4	4000	32000	10300
	75	18.7	3800	8.0	4000	32000	11300
	101.3	13.8	3800	5.9	4000	32000	14100
	121.6	11.5	3800	4.9	4000	32000	17000

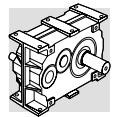

$n_1 = 900$	i	n_2 min^{-1}	Mn_2 Nm	Pn_1 kW	Rn_1 N	Rn_2 N 	Rn_2 N 
RAP 70	10	90	3300	33	4800	25000	2500
	12.2	74	3300	27	5500	27000	4400
	15	60	3400	22	5200	29000	4400
	18.3	49	3400	18.4	5800	32000	6400
	25	36	3600	14.3	5500	32000	6900
	30.4	29.6	3600	11.7	6000	32000	9200
RAP 70 D	45	20.0	3800	8.6	4000	32000	10700
	60.8	14.8	3800	6.4	4000	32000	13400
	75	12.0	3800	5.2	4000	32000	15500
	101.3	8.9	3800	3.8	4000	32000	19000
	121.6	7.4	3800	3.2	4000	32000	22000

$n_1 = 500$	i	n_2 min^{-1}	Mn_2 Nm	Pn_1 kW	Rn_1 N	Rn_2 N 	Rn_2 N 
RAP 70	10	50	3400	18.7	6300	31000	5500
	12.2	41	3400	15.3	6500	32000	7600
	15	33	3600	13.2	6500	32000	7500
	18.3	27.3	3600	10.8	6500	32000	9800
	25	20.0	3800	8.4	6500	32000	10700
	30.4	16.4	3800	6.9	6500	32000	13400
RAP 70 D	45	11.1	3800	4.8	4000	32000	16200
	60.8	8.2	3800	3.5	4000	32000	19600
	75	6.7	3800	2.9	4000	32000	22000
	101.3	4.9	3800	2.1	4000	32000	26000
	121.6	4.1	3800	1.8	4000	32000	29000



$n_1 = 1400$	i	n_2 min^{-1}	Mn_2 Nm	Pn_1 kW	Rn_1 N	Rn_2 N 	Rn_2 N 
RAP 90	10	140	5500	85	3400	36500	2100
	12.5	112	5500	68	4500	40500	4300
	15	93	6100	63	3600	41500	3000
	18.8	74	6100	50	4700	46000	5600
	25	56	6300	39	4100	50500	6800
	31.3	45	6300	31	5100	55500	9700
RAP 90 D	45	31	6600	23	5000	63000	11900
	60.8	23.0	6600	17.2	5000	65000	15500
	75	18.7	7000	14.8	5000	65000	16900
	101.3	13.8	7000	10.9	5000	65000	21000
	121.6	11.5	7000	9.1	5000	65000	26000



$n_1 = 900$	i	n_2 min^{-1}	Mn_2 Nm	Pn_1 kW	Rn_1 N	Rn_2 N 	Rn_2 N 
RAP 90	10	90	6100	60	4000	42000	3300
	12.5	72	6100	48	5300	47000	5900
	15	60	6300	42	4700	49000	6100
	18.8	48	6300	33	5900	54000	9000
	25	36	6600	26	5100	59000	10300
	31.3	28.8	6600	21	6200	65000	13600
RAP 90 D	45	20.0	7000	15.8	5000	65000	16000
	60.8	14.8	7000	11.7	5000	65000	20000
	75	12.0	7000	9.5	5000	65000	23000
	101.3	8.9	7000	7.0	5000	65000	28000
	121.6	7.4	7000	5.9	5000	65000	33000

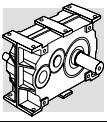

$n_1 = 500$	i	n_2 min^{-1}	Mn_2 Nm	Pn_1 kW	Rn_1 N	Rn_2 N 	Rn_2 N 
RAP 90	10	50	6300	34.7	5900	53000	7900
	12.5	40	6300	27.7	7200	58000	10900
	15	33	6600	24.2	6500	61000	11100
	18.8	26.6	6600	19.3	7700	65000	15000
	25	20.0	7000	15.4	6900	65000	16000
	31.3	16.0	7000	12.3	8000	65000	20000
RAP 90 D	45	11.1	7000	8.8	5000	65000	25000
	60.8	8.2	7000	6.5	5000	65000	30000
	75	6.7	7000	5.3	5000	65000	34000
	101.3	4.9	7000	3.9	5000	65000	40000
	121.6	4.1	7000	3.3	5000	65000	45000





RAP 100



15000 Nm



$n_1 = 1400$	i	n_2 min^{-1}	Mn_2 Nm	Pn_1 kW	Rn_1 N	Rn_2 N 	Rn_2 N 
RAP 100	10.0	140	11000	170	5400	33500	33500
	12.3	114	11000	138	7400	38000	39000
	15.0	93	13000	134	4900	37000	36000
	18.5	76	13000	108	7100	42000	42000
	20.5	68	11000	83	9200	48500	51000
	25.0	56	13500	83	5800	46500	47000
	30.8	45	13500	68	7700	52000	54000
34.2	41	11000	50	10000	60000	64000	
RAP 100 D	41.0	34	11000	42	7000	64500	70000
	45.0	31	14500	51	7000	58500	61000
	50.0	28.0	14500	46	7000	61500	64000
	55.4	25.3	13500	39	7000	67000	71000
	60.8	23.0	14500	38	7000	67000	70000
	75.0	18.7	14500	31	7000	73500	75000
	83.1	16.8	11000	21	7000	75000	75000
	101.3	13.8	14500	23	7000	75000	75000
124.7	11.2	13500	17.1	7000	75000	75000	
138.5	10.1	11000	12.6	7000	75000	75000	

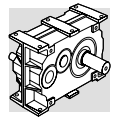

$n_1 = 900$	i	n_2 min^{-1}	Mn_2 Nm	Pn_1 kW	Rn_1 N	Rn_2 N 	Rn_2 N 
RAP 100	10.0	90	11880	118	6800	40000	40000
	12.3	73	11880	96	9000	45000	46000
	15.0	60	14040	93	6400	44000	44000
	18.5	49	14040	75	8700	49000	50000
	20.5	44	11880	57	10000	57000	60000
	25.0	36	14580	58	7200	55000	56000
	30.8	29.2	14580	47	9400	61000	63000
34.2	26.3	11880	34	10000	70000	75000	
RAP 100 D	41.0	22.0	11880	29	7000	75000	75000
	45.0	20.0	15660	35	7000	69000	72000
	50.0	18.0	15660	32	7000	72000	75000
	55.4	16.2	14580	27	7000	75000	75000
	60.8	14.8	15660	26	7000	75000	75000
	75.0	12.0	15660	21	7000	75000	75000
	83.1	10.8	11880	14.5	7000	75000	75000
	101.3	8.9	15660	15.7	7000	75000	75000
124.7	7.2	14580	11.9	7000	75000	75000	
138.5	6.5	11880	8.7	7000	75000	75000	

$n_1 = 500$	i	n_2 min^{-1}	Mn_2 Nm	Pn_1 kW	Rn_1 N	Rn_2 N 	Rn_2 N 
RAP 100	10.0	50	12650	70	9600	51000	52000
	12.3	41	12650	57	10000	56000	59000
	15.0	33	14950	55	9100	56000	57000
	18.5	27.0	14950	44	10000	62000	65000
	20.5	24.4	12650	34	10000	71000	75000
	25.0	20.0	15520	34	10000	69000	72000
	30.8	16.2	15520	28	10000	75000	75000
34.2	14.6	12650	20	10000	75000	75000	
RAP 100 D	41.0	12.2	12650	17.4	7000	75000	75000
	45.0	11.1	16670	20.9	7000	75000	75000
	50.0	10.0	16670	18.8	7000	75000	75000
	55.4	9.0	15520	15.8	7000	75000	75000
	60.8	8.2	16670	15.5	7000	75000	75000
	75.0	6.7	16670	12.6	7000	75000	75000
	83.1	6.0	12650	8.6	7000	75000	75000
	101.3	4.9	16670	9.3	7000	75000	75000
124.7	4.0	15520	7.0	7000	75000	75000	
138.5	3.6	12650	5.2	7000	75000	75000	



$n_1 = 1400$	i	n_2 min^{-1}	Mn_2 Nm	Pn_1 kW	Rn_1 N	Rn_2 N 	Rn_2 N 
RAP 110	10	140	16000	247	1200	44000	45000
	12.3	114	16000	201	5800	51000	54000
	15	93	17500	180	2600	50500	52000
	18.5	76	17500	146	6300	58500	62000
	20.5	68	17500	132	7400	62000	66000
	25	56	20000	123	1600	59500	62000
	30.8	45	20000	100	6200	69000	73000
	34.2	41	17500	79	8600	73000	84000
RAP 110 D	41	34	17500	67	8000	83500	90000
	45	31	22000	77	8000	74500	79000
	50	28.0	22000	70	8000	78500	83000
	55.4	25.3	20000	57	8000	89000	90000
	60.8	23.0	22000	57	8000	85500	90000
	75	18.7	22000	46	8000	90000	90000
	83.1	16.8	17500	33	8000	90000	90000
	101.3	13.8	22000	34	8000	90000	90000
	124.7	11.2	20000	25	8000	90000	90000
138.5	10.1	17500	20	8000	90000	90000	



$n_1 = 900$	i	n_2 min^{-1}	Mn_2 Nm	Pn_1 kW	Rn_1 N	Rn_2 N 	Rn_2 N 
RAP 110	10	90	17280	171	3900	52000	54000
	12.3	73	17280	139	7300	60000	63000
	15	60	18900	125	5100	60000	62000
	18.5	49	18900	101	7900	69000	73000
	20.5	44	18900	91	9100	73000	78000
	25	36	21600	86	4500	70000	74000
	30.8	29.2	21600	69	7700	81000	86000
	34.2	26.3	18900	55	10000	90000	90000
RAP 110 D	41	22.0	18900	47	8000	90000	90000
	45	20.0	23760	54	8000	88000	90000
	50	18.0	23760	48	8000	90000	90000
	55.4	16.2	21600	40	8000	90000	90000
	60.8	14.8	23760	40	8000	90000	90000
	75	12.0	23760	32	8000	90000	90000
	83.1	10.8	18900	23	8000	90000	90000
	101.3	8.9	23760	24	8000	90000	90000
	124.7	7.2	21600	17.6	8000	90000	90000
138.5	6.5	18900	13.9	8000	90000	90000	

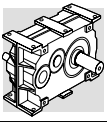

$n_1 = 500$	i	n_2 min^{-1}	Mn_2 Nm	Pn_1 kW	Rn_1 N	Rn_2 N 	Rn_2 N 
RAP 110	10	50	18400	101	7300	66000	70000
	12.3	41	18400	82	10000	75000	81000
	15	33	20120	74	8000	76000	81000
	18.5	27.0	20120	60	11000	86000	90000
	20.5	24.4	20120	54	12000	90000	90000
	25	20.0	23000	51	8000	89000	90000
	30.8	16.2	23000	41	11000	90000	90000
	34.2	14.6	20120	32	13000	90000	90000
RAP 110 D	41	12.2	20120	28	8000	90000	90000
	45	11.1	25300	32	8000	90000	90000
	50	10.0	25300	29	8000	90000	90000
	55.4	9.0	23000	23	8000	90000	90000
	60.8	8.2	25300	24	8000	90000	90000
	75	6.7	25300	19.1	8000	90000	90000
	83.1	6.0	20120	13.7	8000	90000	90000
	101.3	4.9	25300	14.1	8000	90000	90000
	124.7	4.0	23000	10.4	8000	90000	90000
138.5	3.6	20120	8.2	8000	90000	90000	





RAP 130

35000 Nm

$n_1 = 1400$	i	n_2 min^{-1}	Mn_2 Nm	Pn_1 kW	Rn_1 N	Rn_2 N 	Rn_2 N 
RAP 130	9.9	141	23000	358	4400	69000	119000
	12.9	109	23000	275	8100	81000	130000
	14.8	95	25000	260	5200	81000	130000
	18.9	74	25000	204	8800	95000	130000
	24.7	57	30000	187	4000	91000	130000
	31.5	44	30000	147	7900	108000	130000
	34.6	40	30000	134	9100	114000	130000
	37.8	37	30000	126	10000	118000	130000
RAP 130 D	41.5	34	30000	114	10000	125000	130000
	49.4	28.3	30000	96	10000	130000	130000
	63.1	22.2	34000	85	10000	130000	130000
	69.2	20.2	32000	73	10000	130000	130000
	74.1	18.9	34000	73	10000	130000	130000
	94.6	14.8	34000	57	10000	130000	130000
	103.8	13.5	32000	49	10000	130000	130000
	123.4	11.3	34000	44	10000	130000	130000
	157.7	8.9	34000	34	10000	130000	130000
172.9	8.1	32000	29	10000	130000	130000	

$n_1 = 900$	i	n_2 min^{-1}	Mn_2 Nm	Pn_1 kW	Rn_1 N	Rn_2 N 	Rn_2 N 
RAP 130	9.9	90.9	24840	249	6100	83000	130000
	12.9	69.8	24840	191	10100	97000	130000
	14.8	60.8	27000	181	7000	97000	130000
	18.9	47.6	27000	142	10800	112000	130000
	24.7	36.4	32400	130	5800	110000	130000
	31.5	28.6	32400	102	9900	128000	130000
	34.6	26.0	32400	93	11200	130000	130000
	37.8	23.8	32400	87	10000	130000	130000
RAP 130 D	41.5	21.7	32400	79	10000	130000	130000
	49.4	18.2	32400	67	10000	130000	130000
	63.1	14.3	36720	59	10000	130000	130000
	69.2	13.0	34560	51	10000	130000	130000
	74.1	12.1	36720	50	10000	130000	130000
	94.6	9.5	36720	39	10000	130000	130000
	103.8	8.7	34560	34	10000	130000	130000
	123.4	7.3	36720	30	10000	130000	130000
	157.7	5.7	36720	24	10000	130000	130000
172.9	5.2	34560	20	10000	130000	130000	

$n_1 = 500$	i	n_2 min^{-1}	Mn_2 Nm	Pn_1 kW	Rn_1 N	Rn_2 N 	Rn_2 N 
RAP 130	9.9	50.5	26450	147	9600	108000	130000
	12.9	38.8	26450	113	14000	124000	130000
	14.8	33.8	28750	107	10600	125000	130000
	18.9	26.5	28750	84	14600	130000	130000
	24.7	20.2	34500	77	9300	130000	130000
	31.5	15.9	34500	60	13700	130000	130000
	34.6	14.5	34500	55	15000	130000	130000
	37.8	13.2	34500	52	10000	130000	130000
RAP 130 D	41.5	12.0	34500	47	10000	130000	130000
	49.4	10.1	34500	39	10000	130000	130000
	63.1	7.9	39100	35	10000	130000	130000
	69.2	7.2	36800	30	10000	130000	130000
	74.1	6.7	39100	30	10000	130000	130000
	94.6	5.3	39100	23	10000	130000	130000
	103.8	4.8	36800	20	10000	130000	130000
	123.4	4.1	39100	17.9	10000	130000	130000
	157.7	3.2	39100	14.0	10000	130000	130000
172.9	2.9	36800	12.0	10000	130000	130000	

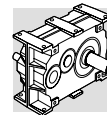

8 - DIMENSIONI D'INGOMBRO

8 - INSTALLATION DRAWINGS

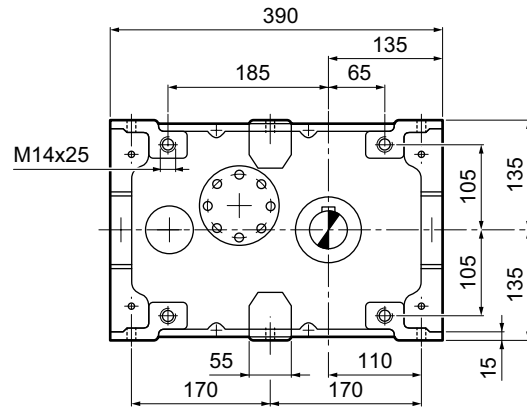
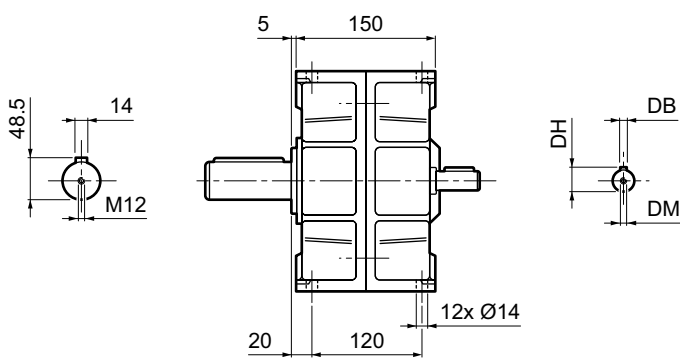
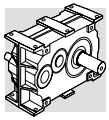

N

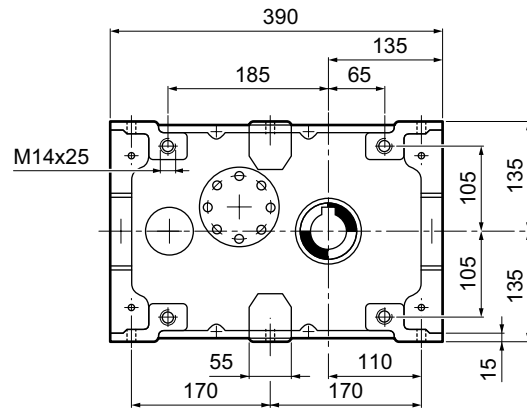
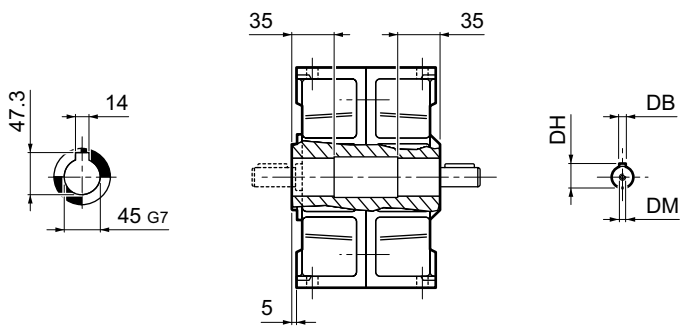
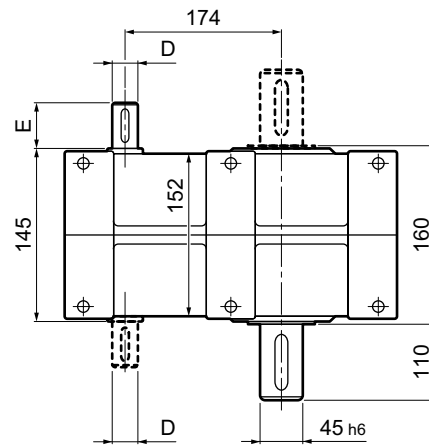

C

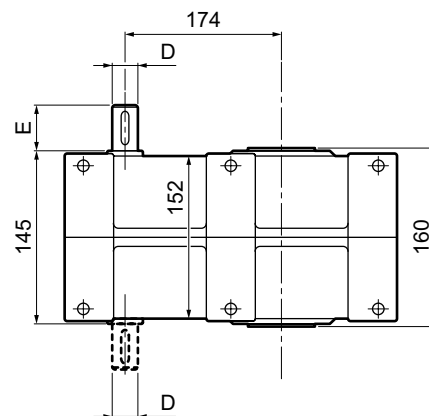

RAP 45

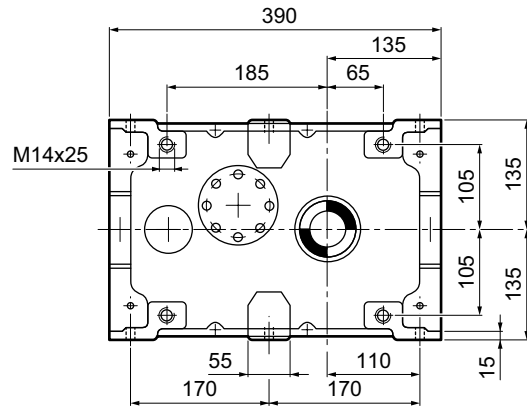
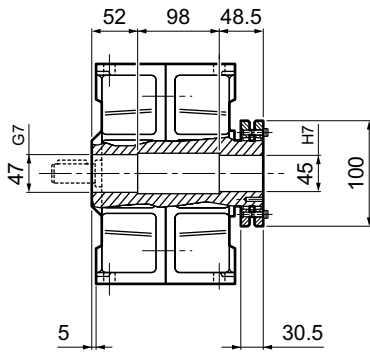
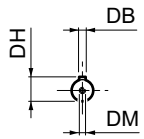
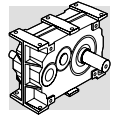

CC

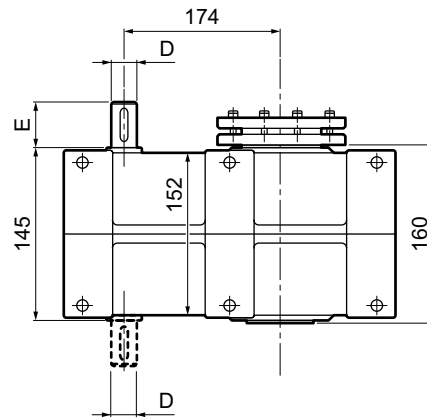

	D h6	DB	DH	DM	E	Kg
RAP 45	24	8	27	M8	50	42
RAP 45 D	19	6	21.5	M6	40	45

	Z
INPUT	RAP 45 - RAP 45 D
080	251
090	251
100/112	263
132	283

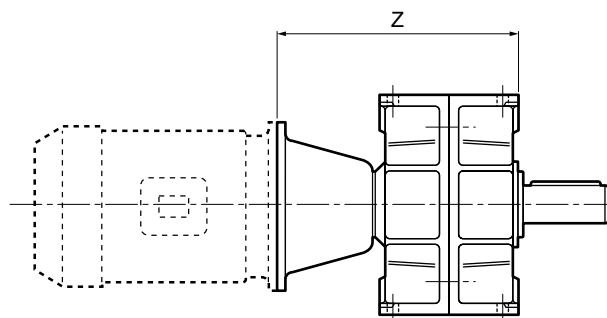

P(IEC)

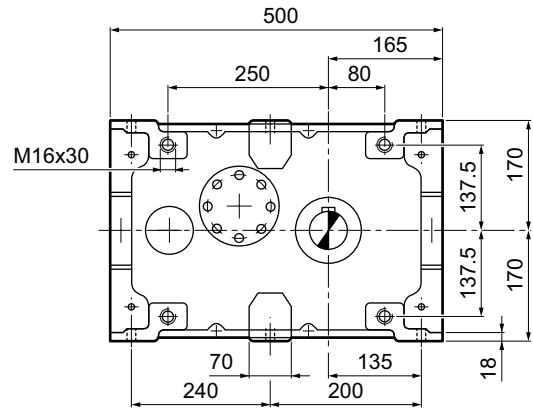
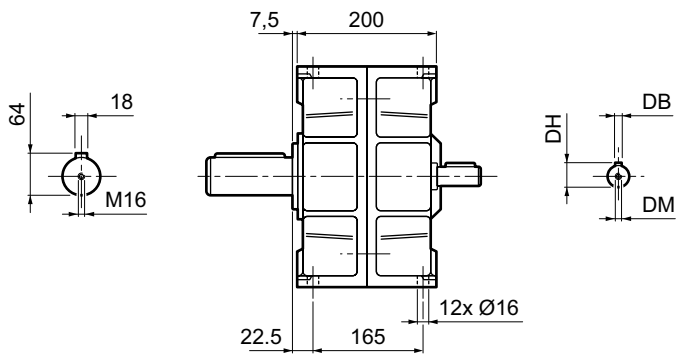
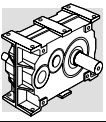

N

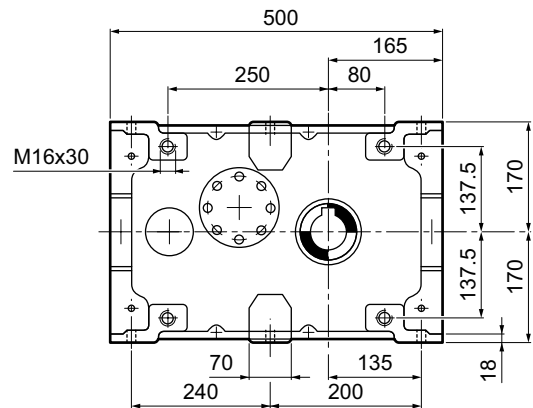
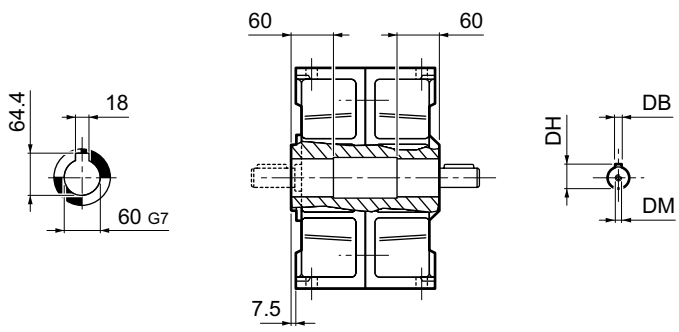
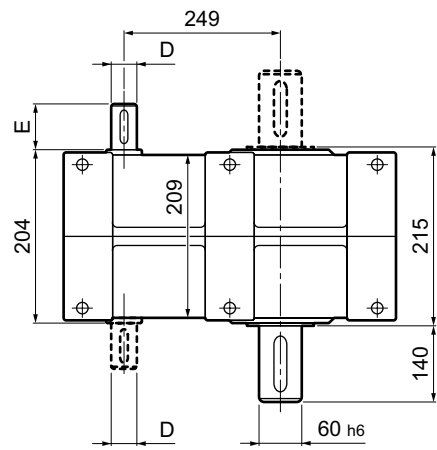

C

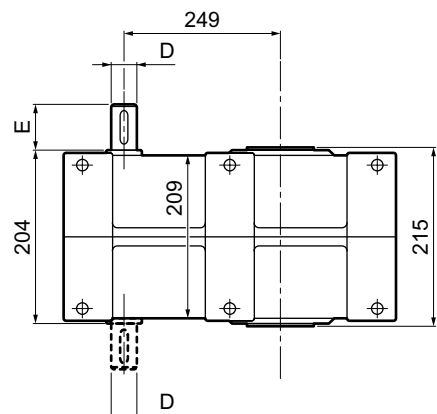

RAP 60

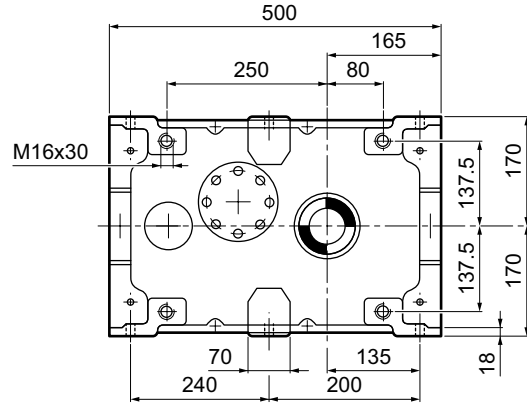
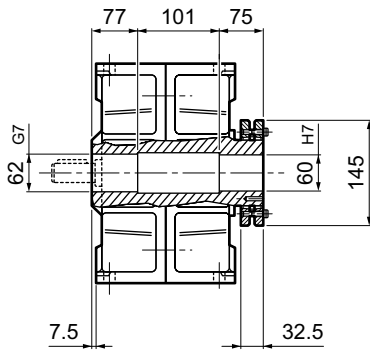
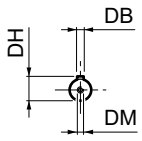
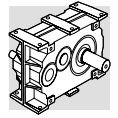

CC

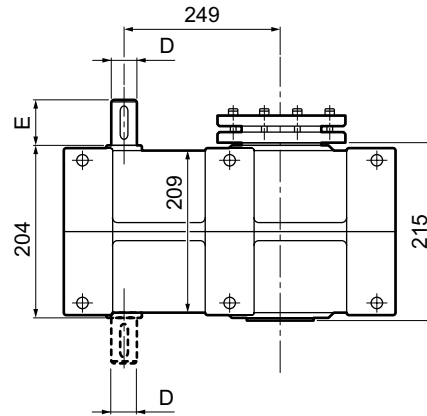

	D h6	DB	DH	DM	E	Kg
RAP 60	38	10	41	M12	80	85
RAP 60 D	28	8	31	M10	60	95

	Z
INPUT	RAP 60 - RAP 60 D
100/112	387
132	367
160	397

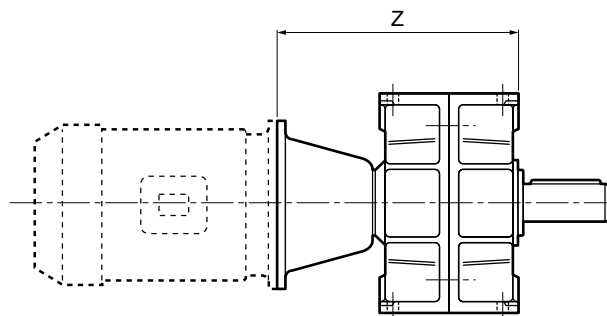

P(IEC)

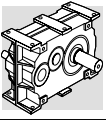

RAP 70

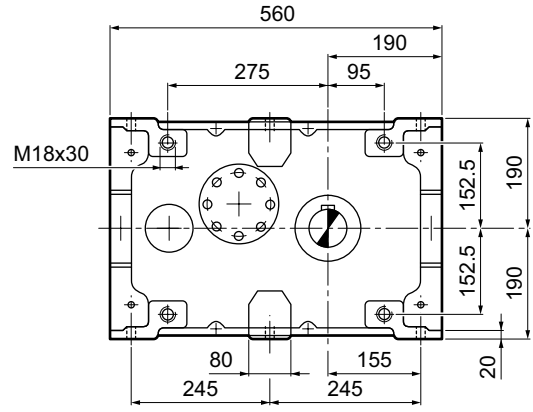
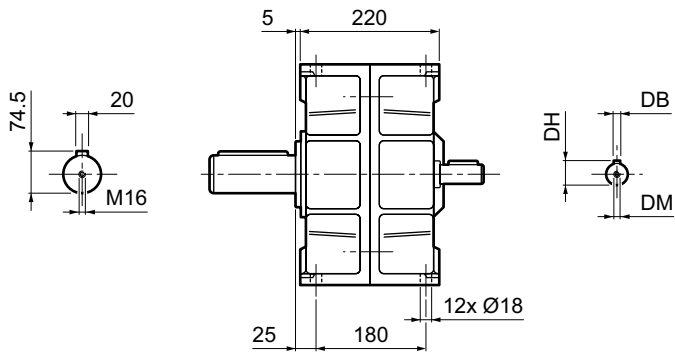

N

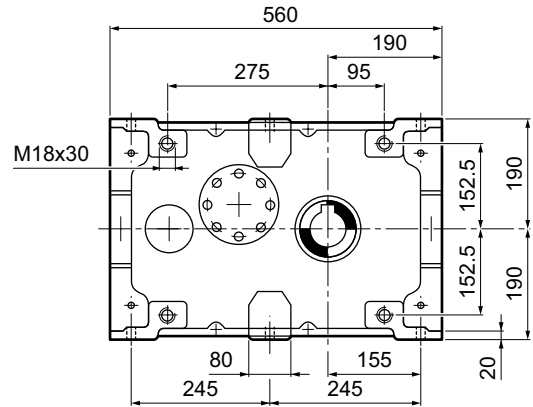
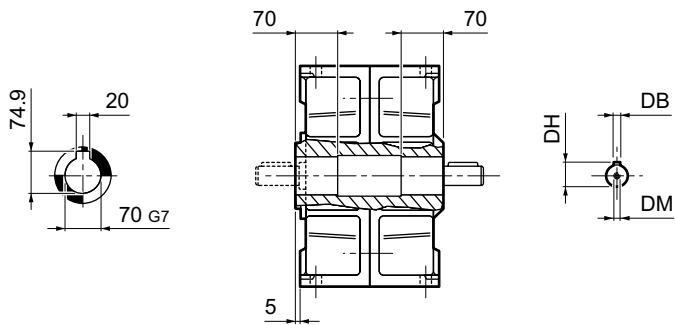
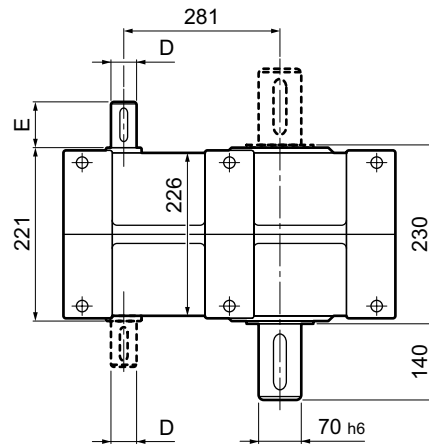

C

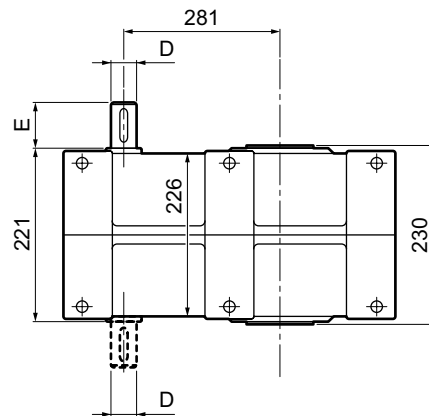

RAP 70

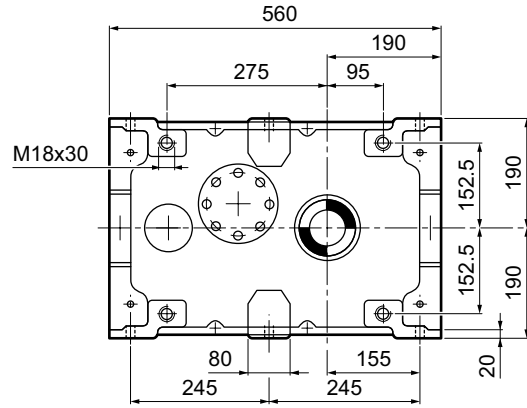
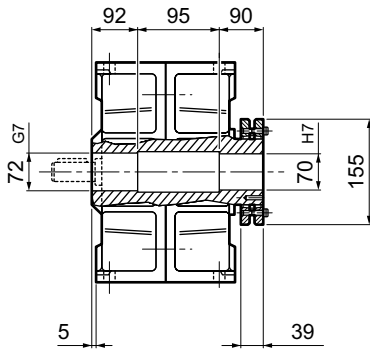
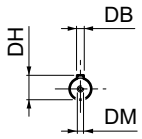
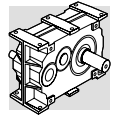

CC

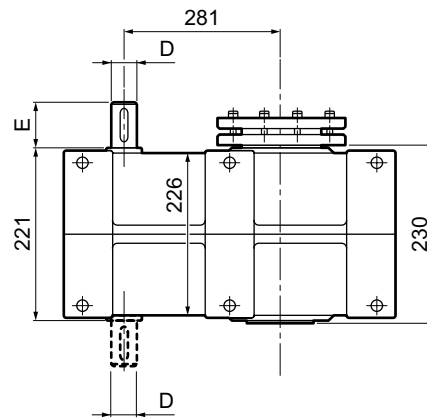

	D h6	DB	DH	DM	E	Ⓚg
RAP 70	38	10	41	M12	80	112
RAP 70 D	28	8	31	M10	60	125

	Z
INPUT	RAP 70 - RAP 70 D
100/112	405
132	385
160	415
180	415

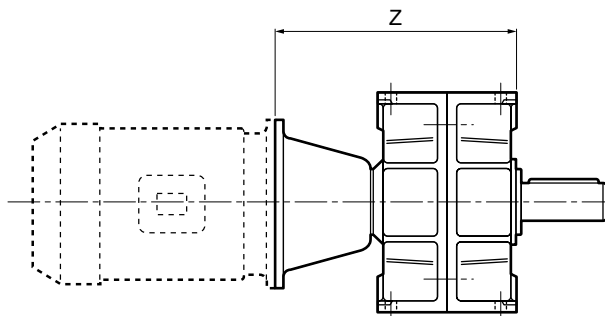

P(IEC)

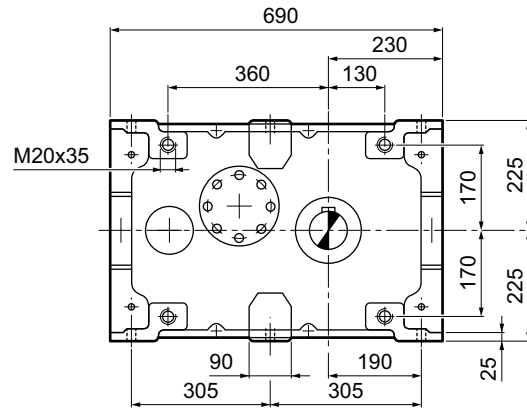
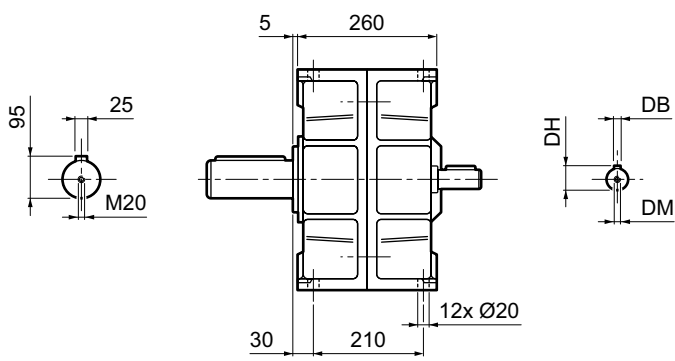
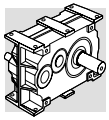

N

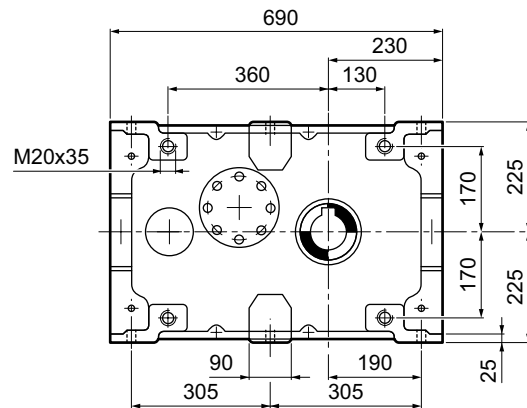
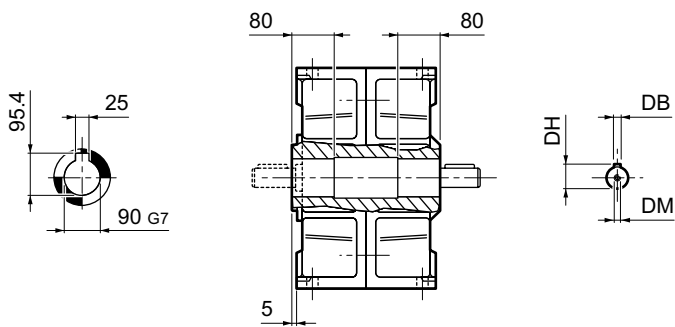
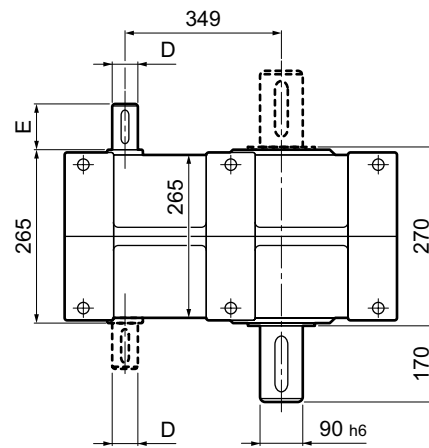

C

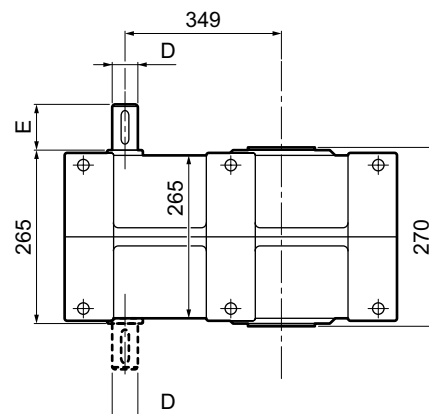

RAP 90

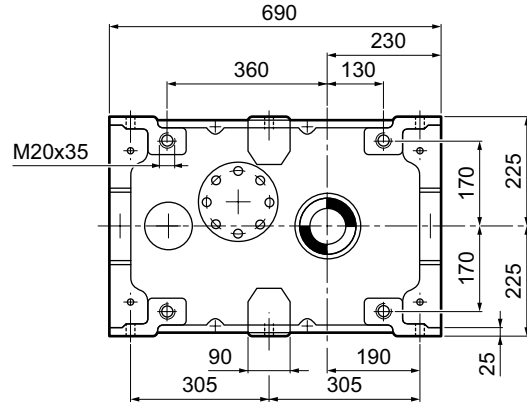
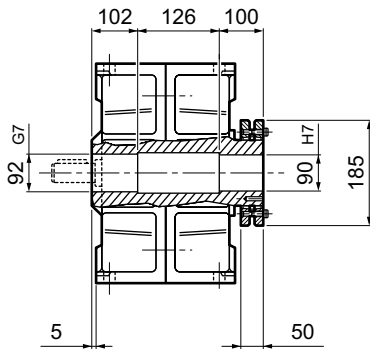
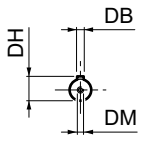
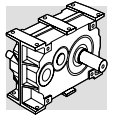

CC

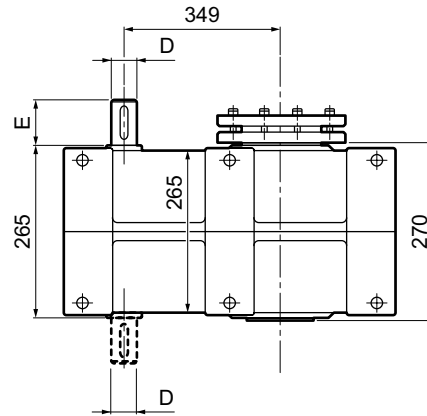

	D h6	DB	DH	DM	E	Kg
RAP 90	48	14	51.5	M16	110	215
RAP 90 D	42	12	45	M12	110	230

	Z
INPUT	RAP 90 - RAP 90 D
132	523
160	498
180	498
200	523

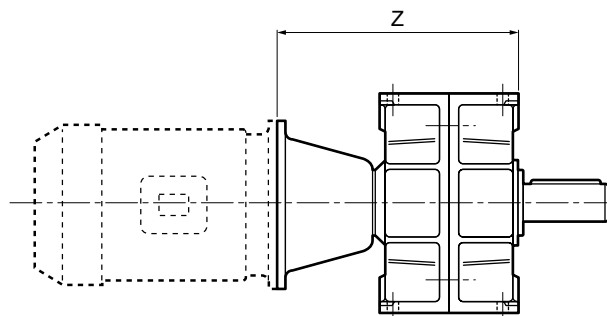

P(IEC)

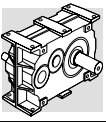

RAP 100

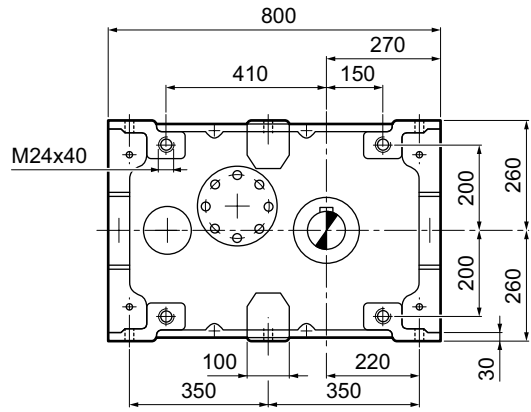
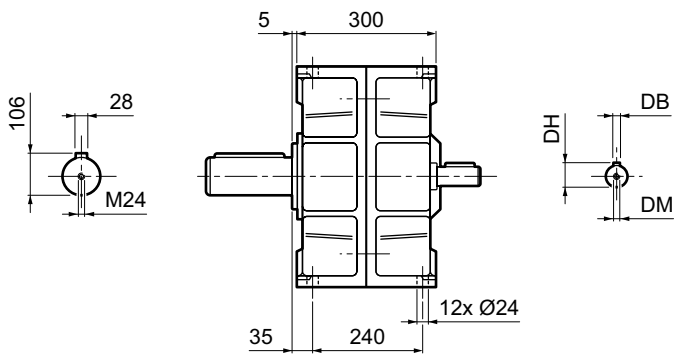

N

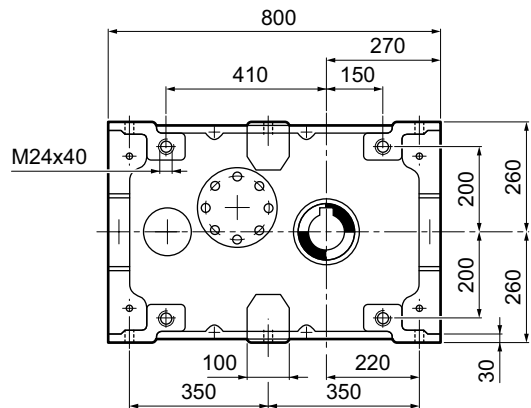
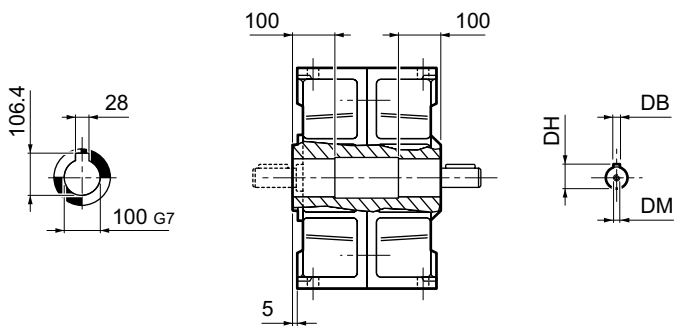
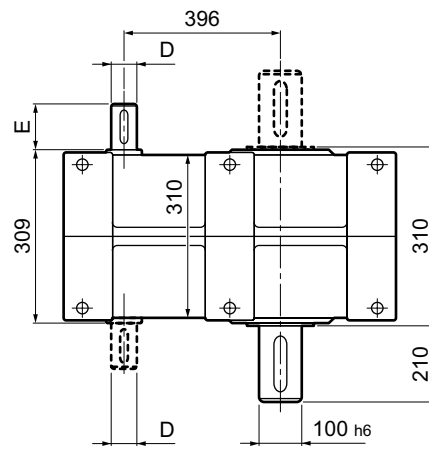

C

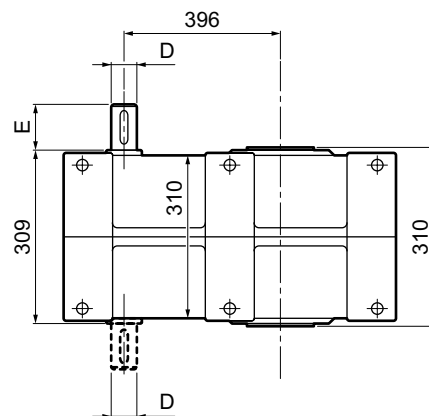

RAP 100

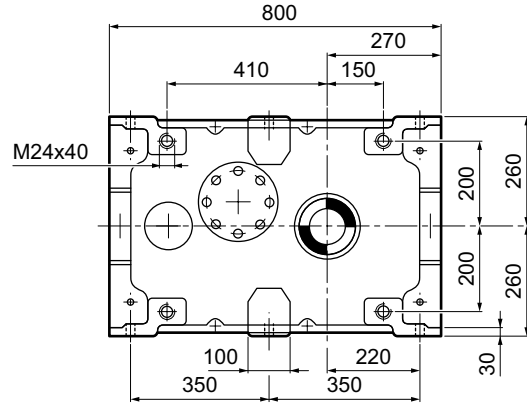
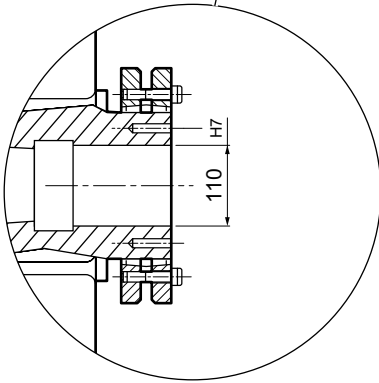
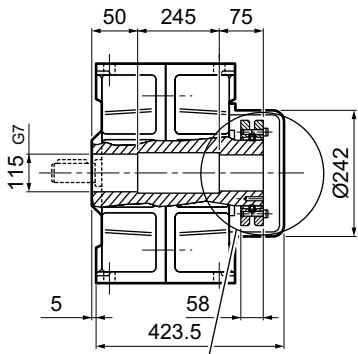
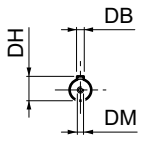
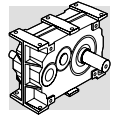

CC

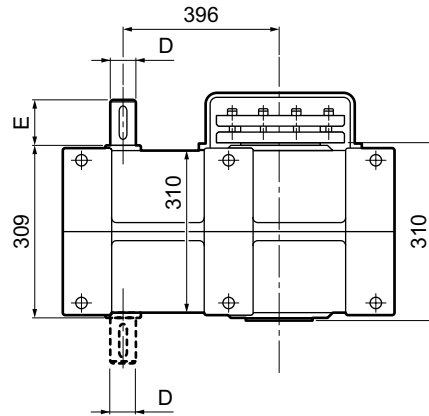

	D h6	DB	DH	DM	E	Kg
RAP 100	48	14	51.5	M16	110	315
RAP 100 D	42	12	45	M12	110	335

	Z
INPUT	RAP 100 - RAP 100 D
132	586
160	586
180	586
200	586
225	561

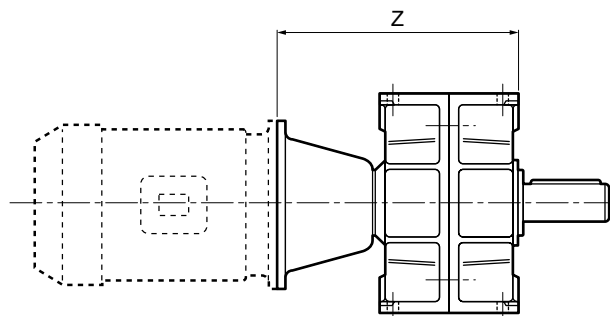

P(IEC)

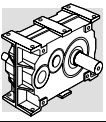

RAP 110

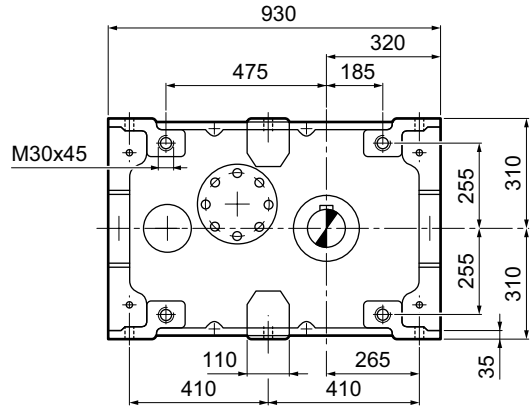
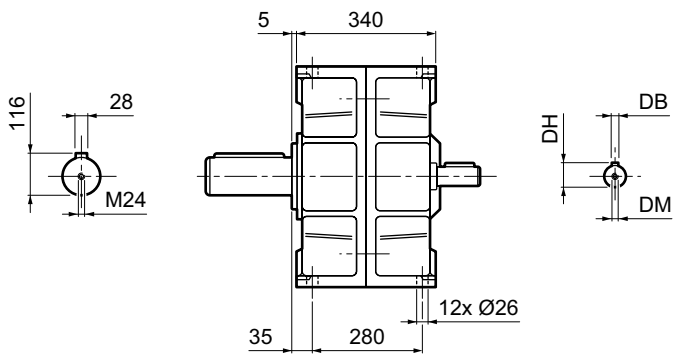

N

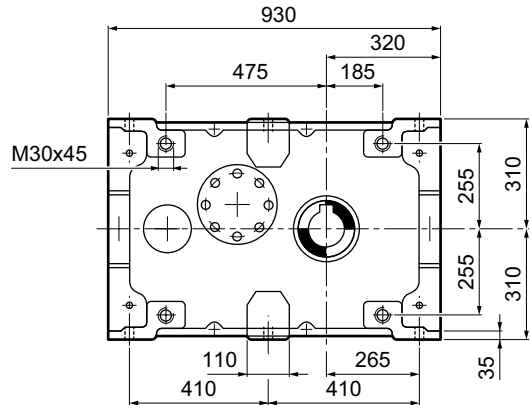
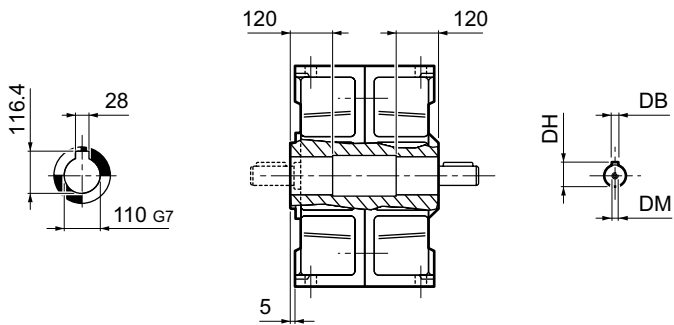
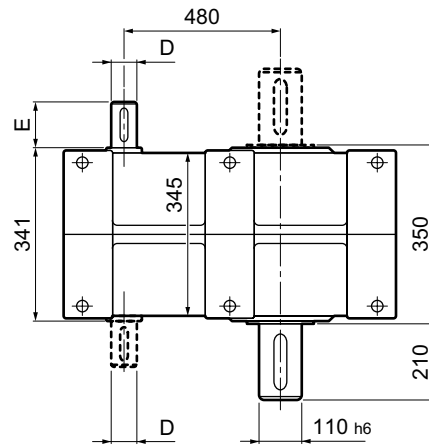

C

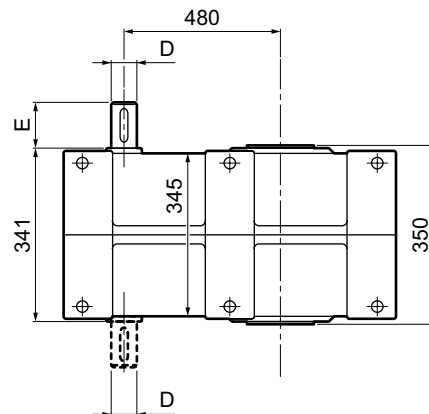

RAP 110

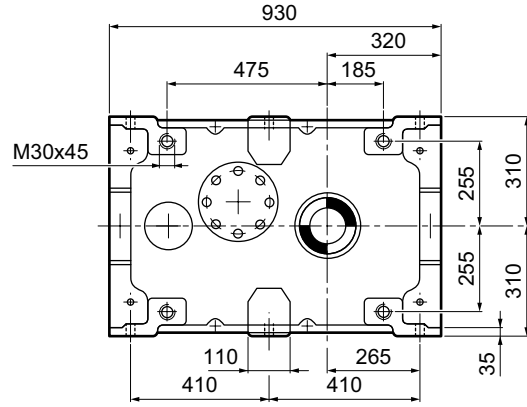
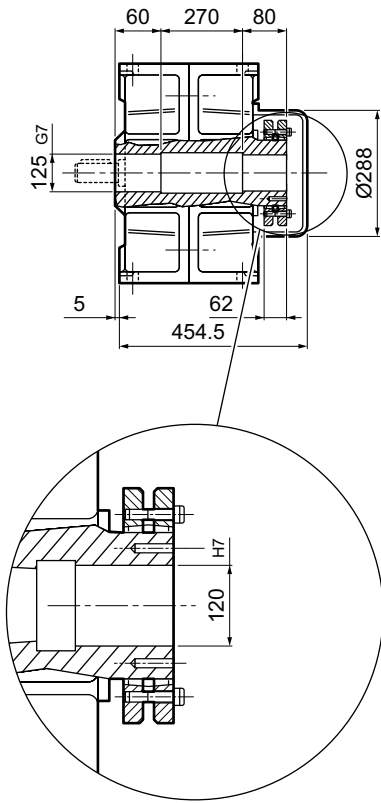
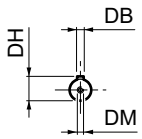
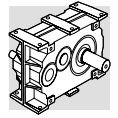

CC

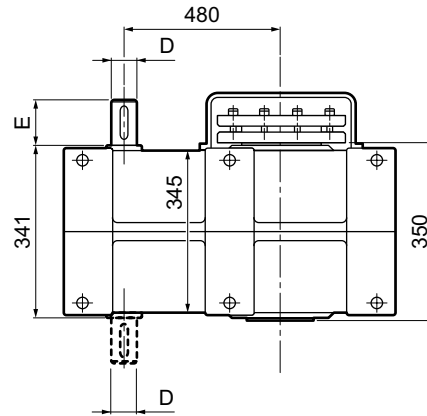

	D h6	DB	DH	DM	E	kg
RAP 110	55	16	59	M16	110	521
RAP 110 D	48	14	51.5	M16	110	545

	Z
INPUT	RAP 110 - RAP 110 D
132	682
160	622
180	622
200	622
225	597
250	627

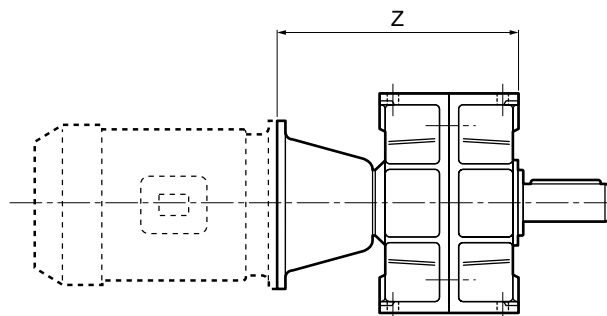

P(IEC)

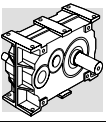

RAP 130

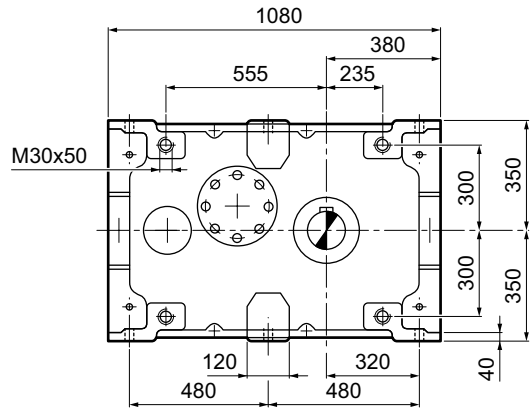
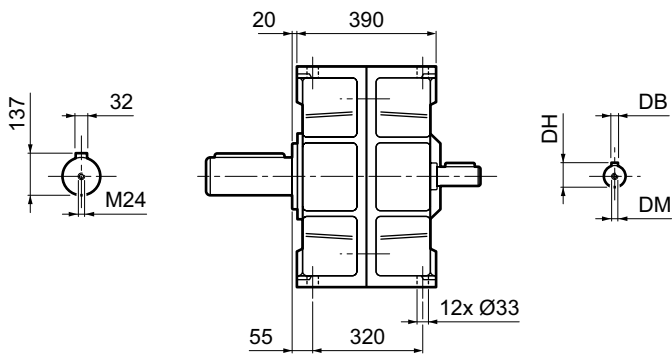

N

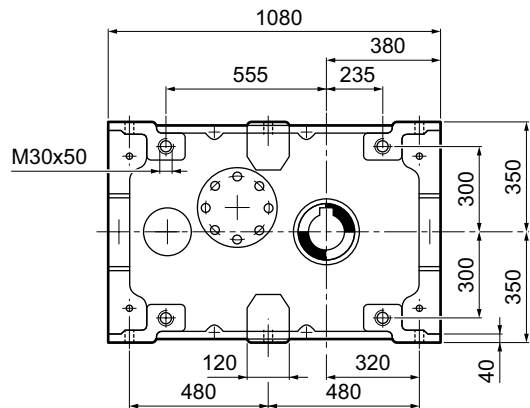
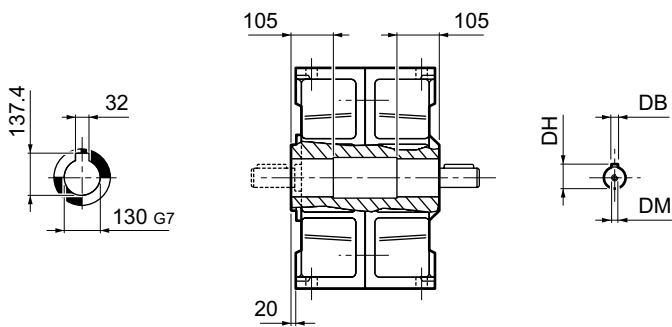
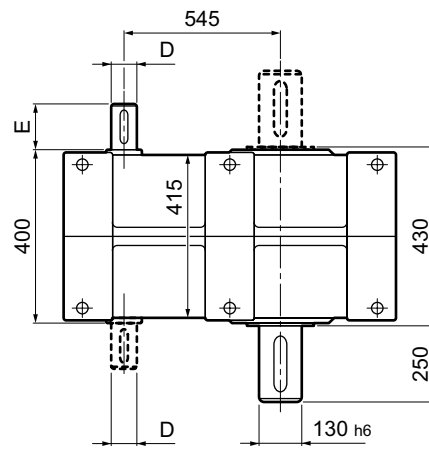

C

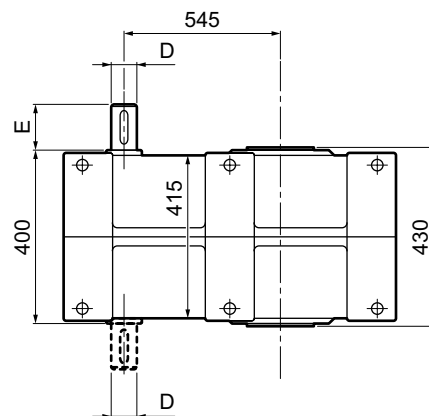

RAP 130

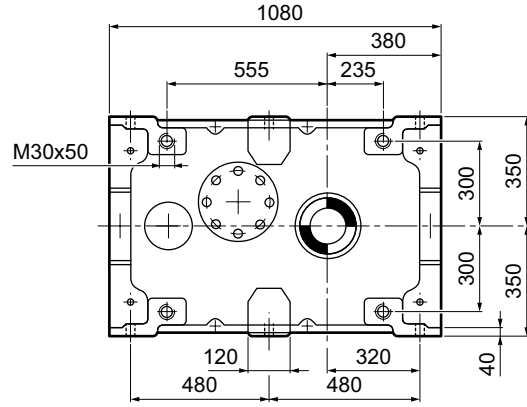
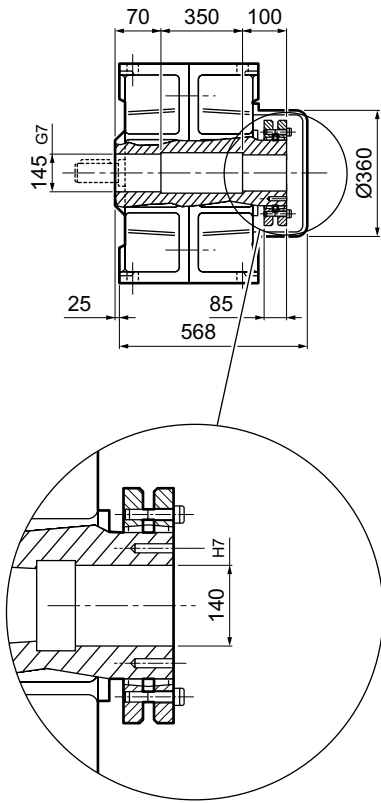
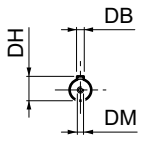
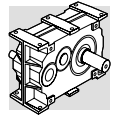

CC

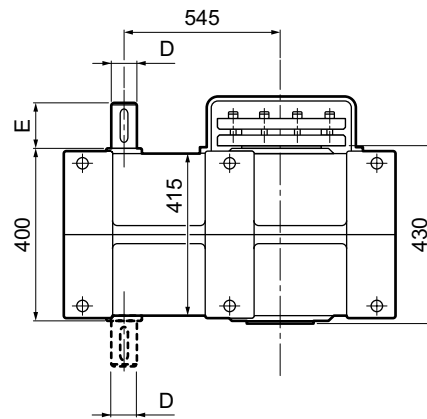

	D h6	DB	DH	DM	E	kg
RAP 130	60	18	64	M16	140	800
RAP 130 D	55	16	59	M16	110	855

	Z
INPUT	RAP 130 - RAP 130 D
160	708
180	708
200	708
225	683
250	713
280	713

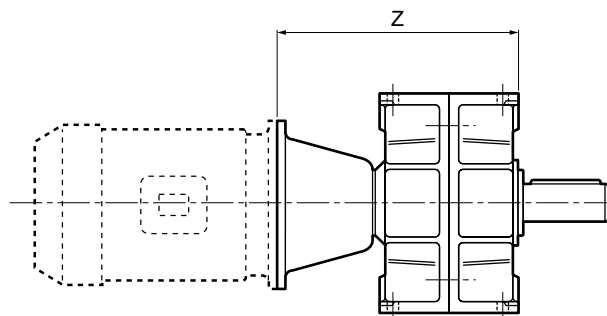

P(IEC)

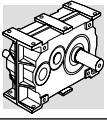

9 - PERNO MACCHINA

Nel realizzare l'albero condotto che si accoppierà con il riduttore consigliamo di utilizzare acciaio di buona qualità e di realizzare le dimensioni come suggerito nello schema seguente.

Suggeriamo inoltre di completare il montaggio con un dispositivo che realizza il bloccaggio assiale dell'albero (non illustrato).

9 - CUSTOMER'S SHAFT

Pivot of driven equipment should be made from high grade alloy steel. Table below shows recommended dimensions for the Customer to consider when designing mating shaft.

A device retaining the shaft axially is also recommended (not shown).

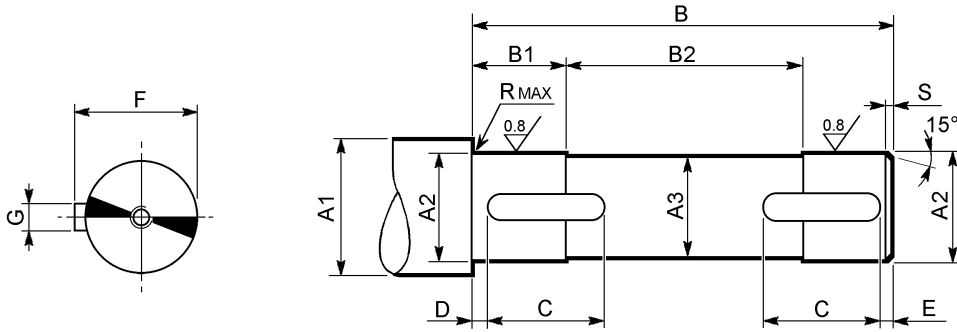

	A1	A2	A3	B	B1	B2	C	D	E	F	G	R	S
RAP 45	≥ 58	45 h7	44	158	33	90	60	2.5	2.5	47	14	1	2
RAP 60	≥ 76	60 h7	59	213	58	95	70	2.5	2.5	64	18	2.5	2
RAP 70	≥ 87	70 f7	69	228	68	90	80	2.5	2.5	74.5	20	2.5	2
RAP 90	≥ 112	90 f7	89	268	78	110	100	3	3	95	25	2.5	2.5
RAP 100	≥ 118	100 f7	99	308	98	110	150	3	3	106	28	2.5	2.5
RAP 110	≥ 121	110 f7	109	347	117	113	150	5	5	116	28	2.5	3
RAP 130	≥ 143	130 f7	129	437	102	223	180	5	5	137	32	2.5	3

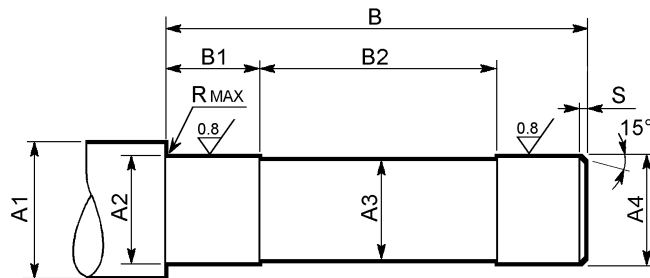

	A1	A2	A3	A4	B	B1	B2	R	S
RAP 45	≥ 58	47 h7	44	45 g6	196,5	50	98	1	2
RAP 60	≥ 76	62 h7	59	60 g6	251	75	101	2,5	2
RAP 70	≥ 87	72 h7	69	70 g6	275	90	95	2,5	2
RAP 90	≥ 112	92 h7	89	90 g6	326	100	126	2,5	3
RAP 100	≥ 142	115 h7	109	110 g6	368	48	245	2,5	3
RAP 110	≥ 155	125 h7	119	120 g6	407	57	270	2,5	3
RAP 130	≥ 184	145 h7	139	140 g6	517	67	350	2,5	3

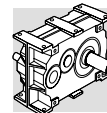

10 - INSTALLAZIONE RIDUTTORE CON CALETTATORE

10 - INSTALLATION OF THE SHRINK DISC

	EH	EL	EM	EN	Viti Bolts	Mt [Nm]
RAP 45 RAP 45 D	—	—	100	30.5	M6x25	15
RAP 60 RAP 60 D	—	—	145	32.5	M8x30	40
RAP 70 RAP 70 D	—	—	155	39	M8x35	40
RAP 90 RAP 90 D	—	—	185	50	M10x40	83
RAP 100 RAP 100 D	126	M8x20	230	58	M12x45	130
RAP 110 RAP 110 D	137	M8x20	265	62	M12x50	130
RAP 130 RAP 130 D	162	M10x25	330	85	M16x65	325

**MONTAGGIO
ASSEMBLING**

**SMONTAGGIO
REMOVAL**

Schema di assemblaggio

- 1) Svitare le viti di bloccaggio gradualmente e in successione rimuovendo il calettatore.
- 2) Pulire e sgrassare bene le zone di accoppiamento fra albero lento riduttore e albero condotto della macchina. Non oliare od usare solventi.
- 3) Effettuare l'accoppiamento fra albero condotto e il riduttore.
- 4) Applicare il calettatore sull'albero cavo del riduttore.
- 5) Avvitare a fondo tutte le viti del calettatore gradualmente e in successione. È necessario effettuare alcune passate affinché tutte le viti siano avvitate completamente alla coppia di serraggio indicata.

N.B. - I particolari illustrati nelle sequenze di montaggio e smontaggio del calettatore non sono oggetto della fornitura.

Assembly procedure

- 1) Remove the locking bolts, then the shrink disc.
- 2) Clean both the surface of the driven shaft and the inner surface of the hollow shaft thoroughly. Do not use solvents nor lubricants on the mating surfaces.
- 3) Fit the gearbox onto the machine solid shaft.
- 4) Slide the shrink disc over the protrusion of the gearbox hollow shaft.
- 5) Tighten all bolts gradually and in a circular sequence using a torque wrench. Several steps may be required before the tightening torque specified for the gear unit is achieved.

N.B. - Parts for the assembly and disassembly of the gearboxes are out of the scope for supply.

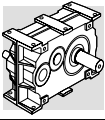

11 - CALCOLO DEL CARICO RADIALE

11 - CALCULATION OF RADIAL LOAD

$$R = \frac{2000 \times M \times K}{D}$$

- R** = Carico radiale (N)
M = Momento torcente sull'albero in esame (Nm)
D = Diametro primitivo (mm) dell'organo di trasmissione calettato sull'albero.
K = 1.0 - Trasmissione a catena
1.25 - Trasmissione a ingranaggio
1.5-2.0 - Trasmissione a cinghia trapezoidale

- R** = Radial load (N)
M = Torque (Nm)
D = PCD (mm) of the transmission element.
K = 1 - Chain transmission
1.25 - Gear transmission
1.5-2.0 - V-belt transmission

Il valore della forza risultante R così ricavata dovrà essere inferiore al valore ammissibile R_n fornito dal catalogo per il dato riduttore.

The resulting force R, so calculated, must be lower in value than the admissible overhung load R_n listed in the catalogue for the specific gear unit.

- I valori dei carichi radiali ammissibili forniti dal catalogo sono riferiti all'applicazione di forze in corrispondenza della mezzeria dell'albero. In caso di forze applicate più esternamente consultare il Servizio Tecnico del costruttore.
- Il valore del carico assiale ammissibile è pari al 20% del corrispondente carico radiale.
- I carichi nominali per velocità diverse da quelle elencate a catalogo si possono ottenere per interpolazione.
- È consigliabile montare la puleggia, la ruota dentata o l'ingranaggio il più vicino possibile alla battuta dell'albero.
- Nel caso di alberi bisporgenti il valore del carico sopportabile da ciascuna estremità è uguale ai 2/3 del valore di tabella, purchè i due carichi siano di uguale intensità e agiscano nello stesso verso.

- *Admissible overhung loads listed in the catalogue apply in the case of forces acting at midpoint of the shaft under study. Should the application point be shifted further out consult BONFIGLIOLI Technical Service.*
- *Admissible thrust load equals 20% of the correspondent overhung load listed in the catalogue.*
- *Nominal ratings for drive speeds not listed in the catalogue may be obtained by interpolation.*
- *To optimize bearing lifetime, mounting of the transmission element as close as possible to shaft shoulder is largely preferred.*
- *In the case of double-extended shafts, the loading which may be taken by each of the shaft ends is equal to 2/3rds of the rated OHL, if the two forces are equal and operate in the same direction.*

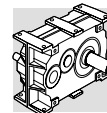

**12 - PREDISPOSIZIONI ATTACCO
MOTORE**

12 - MOTOR ADAPTERS

	GRANDEZZA MOTORE / MOTOR SIZE										
	80	90	100	112	132	160	180	200	225	250	280
RAP 45											
RAP 45 D											
RAP 60											
RAP 60 D											
RAP 70											
RAP 70 D											
RAP 90											
RAP 90 D											
RAP 100											
RAP 100 D											
RAP 110											
RAP 110 D											
RAP 130											
RAP 130 D											

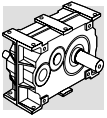

INDICE DELLE REVISIONI (R)

INDEX OF REVISIONS (R)

R1	
Descrizione	Description

Questa pubblicazione annulla e sostituisce ogni precedente edizione o revisione. Ci riserviamo il diritto di apportare modifiche senza preavviso. È vietata la produzione anche parziale senza autorizzazione.

This publication supersedes and replaces any previous edition and revision. We reserve the right to implement modifications without notice. This catalogue cannot be reproduced, even partially, without prior consent.

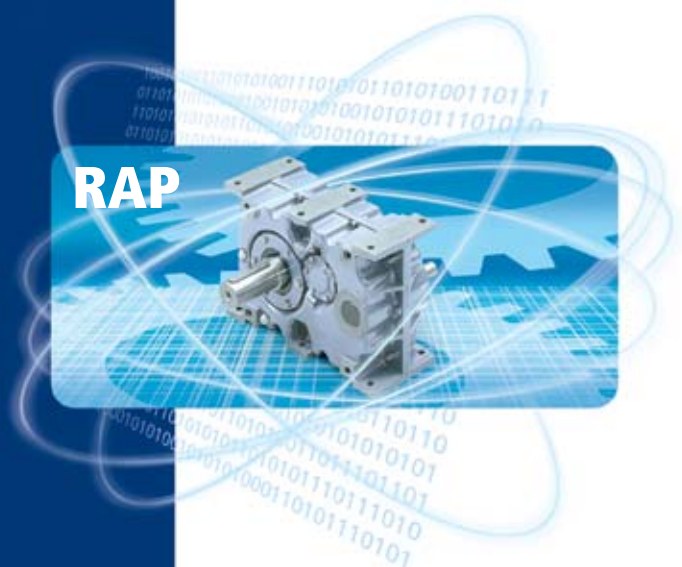

www.bonfiglioli.com

 **BONFIGLIOLI**